

# CITY OF NAPOLEON RESIDENTIAL ZONING PERMIT APPLICATION

THIS APPLICATION IS FOR RESIDENTIAL DEMOLITIONS, FENCES, POOLS, SHEDS,  
DRIVEWAYS, SIDEWALKS & SEWERS

FH 13-0369 Sewer

DATE \_\_\_\_\_ JOB LOCATION 915 Scott ST

OWNER Bernard Dietrich TELEPHONE # 419-966-2996

OWNER ADDRESS 605 Buckeye W.

CONTRACTOR RON MEYERS CELL PHONE # \_\_\_\_\_

DESCRIPTION OF WORK TO BE PERFORMED New Sewer line

ESTIMATED COMPLETION DATE 9-20-2013 ESTIMATED COST \_\_\_\_\_

DESCRIPTION	FEE	TOTAL COST
Demo Permit	(100.3100.46690) \$100.00	\$
Fence	(100.3100.46690) \$25.00	\$
Pool	(100.3100.46690) \$25.00	\$
Garage and Shed Under 200 SF (Detached)	(100.3100.46690) \$25.00	\$
Driveway	0	\$
Sidewalk/Curbing	0	\$
Sewer Outside	0	\$ <span style="border: 1px solid black; border-radius: 50%; padding: 2px;">0</span>
<b>Subtotal:</b>		\$
		\$
<b>TOTAL FEE:</b>		\$ <span style="border: 1px solid black; border-radius: 50%; padding: 2px;">0</span>

**I FULLY UNDERSTAND THAT NO EXCAVATION, CONSTRUCTION OR STRUCTURAL ALTERATION, ELECTRICAL OR MECHANICAL INSTALLATION OR ALTERATION OF ANY BUILDING STRUCTURE, SIGN, OR PART THEREOF AND NO USE OF THE ABOVE SHALL BE UNDERTAKEN OR PERFORMED UNTIL THE PERMIT APPLIED FOR HEREIN HAS BEEN APPROVED AND ISSUED BY THE CITY OF NAPOLEON BUILDING/ZONING DEPARTMENT.**

*I hereby certify that I am the Owner of the named property, or that the proposed work is authorized by the Owner of record and that I have been authorized by the Owner to make this application as his/her authorized agent and I agree to conform to all applicable laws of the jurisdiction. In addition, if a permit for Work described in this application is issued, I certify that the code official or the code official's authorized representative shall have the authority to enter areas covered by such permit at any reasonable hour to enforce the provisions of the code(s) applicable to such permit.*

**I HEREBY ACKNOWLEDGE THAT I HAVE READ AND FULLY UNDERSTAND THE ABOVE LISTED INSTRUCTIONS.**

SIGNATURE OF APPLICANT: Bernard Dietrich DATE: 9-20-2013

PRINT NAME: BERNARD DIETRICH

PERMIT #	BATCH #	CHECK #	DATE
----------	---------	---------	------

CITY OF NAPOLEON  
ENGINEERING DEPT.  
255 W RIVERVIEW  
NAPOLEON, OH 43545

JOB - 915 SCOTT  
SHEET NO 1 OF 1  
CALCULATED BY STJ DATE 4-28-87  
CHECKED BY \_\_\_\_\_ DATE \_\_\_\_\_  
SCALE \_\_\_\_\_

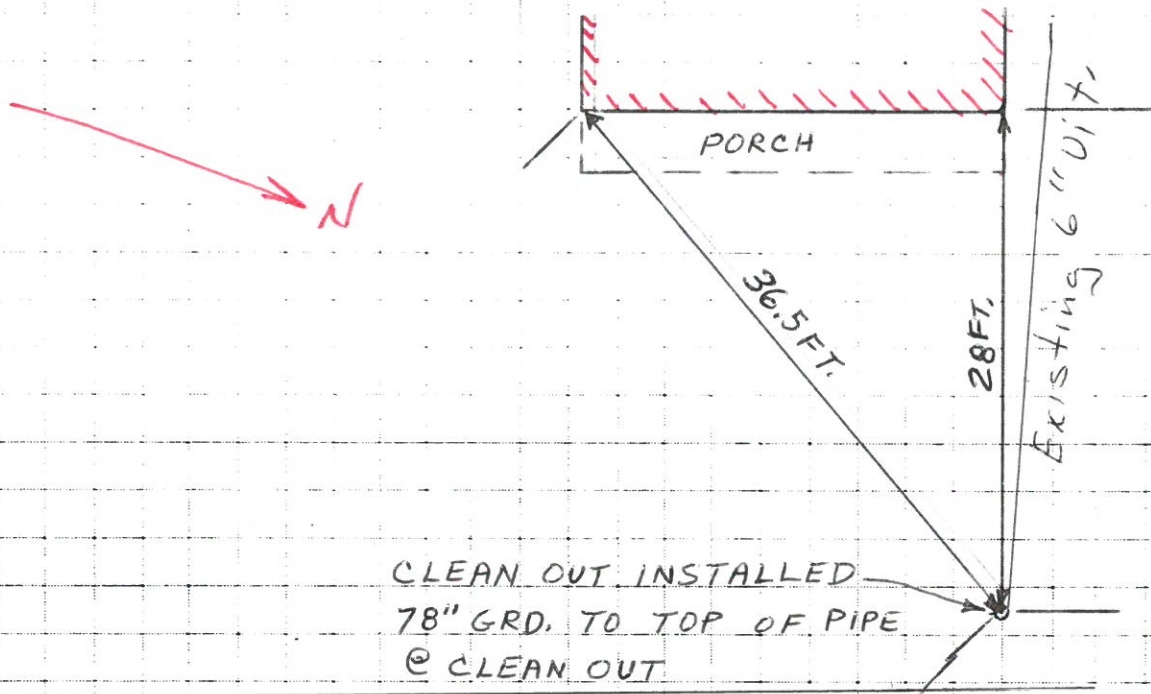

Existing 12" Britz No M.H. upper end

PLAN